

(3) 2 1/2"x 2 1/2"x 3/16"THK. x 23"LG. ANGLE LEGS (STOCK LEGS)  
 (3) 4"x 4"x 1/4"THK. PADS W/ 3/4"Ø HOLES

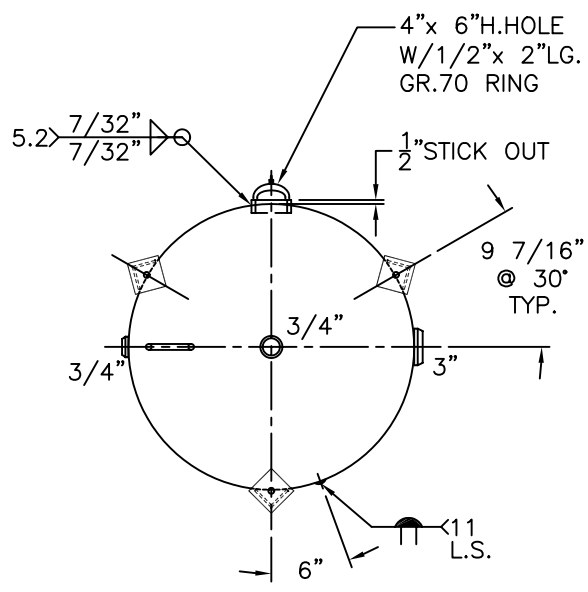

NOTE: 1) HYDRO @ 260 PSIG. MIN.

SHELL / HEADS		.210" SA-455 2:1 S.E.	
JOGGLE			
M.A.W.P.		200 PSIG.	300 °F
M.D.M.T.		-20 °F @	200 PSIG.
ASME. SECTION VIII		DIV. 1, 2001 ADD. 2002	
X-RAY: RT-4 SPOT L.S.			
GALLONS: 400	WT. 787 LBS.		
SERIAL NO.			
INSIDE: GALVANIZED		OUTSIDE: GALVANIZED	
VERT. AIR TANK		FOR: HANSON STANDARD	
I-36-VA-400-L		REV. 6-10-03	
DATE: 9-12-84			
SCALE: 3/4"=12"			
<b>ROY E. HANSON JR. MFG.</b> 1924 COMPTON AVE. LOS ANGELES, CA 90011			